

R-LX-CS-ZF Zinc Flake coated Countersunk Concrete Screw Anchor

Self-tapping concrete screwbolt



Approvals and Reports

- ETA 17/0783
- UKTA-22/6346



Product information

Features and benefits

- Time-efficient installation through streamlined procedure - simply drill and drive
- Completely removable with possibility of reuse
- Unique design with patented threadform ensures high performance for relatively small hole diameter and low torque level during installation even in high strength concrete
- Non-expansion functioning ensures low risk of damage to base material and makes R-LX ideal for installation near edges and adjacent anchors
- Highest performance in both cracked and non-cracked concrete
- Special zinc flake coating for increased corrosion resistance
- Different head types for any application
- Possibility of multiple use in high-strength concrete
- Allround product for any application

Applications

- Through-fixing
- Temporary anchorages
- Formwork support systems
- Balustrading & handrails
- Fencing & gates manufacturing and installation
- Racking systems
- Public seating
- Scaffolding

Base materials

Approved for use in:

- Cracked concrete C20/25-C50/60
- Non-cracked concrete C20/25-C50/60
- Reinforced concrete
- Unreinforced concrete

Installation guide

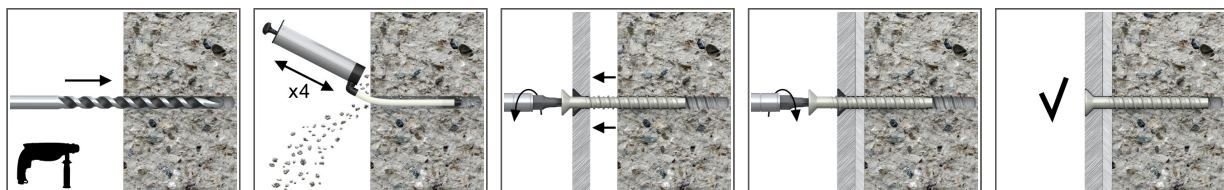

1. Drill the hole with rotary hammer drilling machine. Drill to a required depth.
2. Blow out dust at least 4 times with a hand pump.
3. Possibility of unscrewing and re-screwing.
4. Tighten to the recommended torque.
5. After installation.

Product information

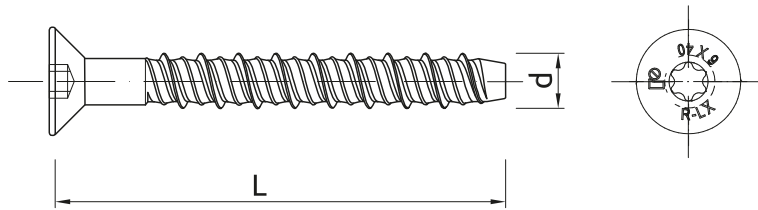

Size	Product Code	Anchor		Fixture		
		Diameter	Length	Max. thickness t_{fix} for:		Hole diameter
		d [mm]	L [mm]	$h_{nom,red}$ [mm]	$h_{nom,std}$ [mm]	d_f [mm]
5	R-LX-05X050-CS-ZF	6.2	50	-	7	7
	R-LX-05X075-CS-ZF	6.2	75	-	32	7
6	R-LX-06X050-CS-ZF	7.5	50	7	-	9
	R-LX-06X075-CS-ZF	7.5	75	32	20	9
	R-LX-06X100-CS-ZF	7.5	100	57	45	9
	R-LX-06X120-CS-ZF	7.5	120	77	65	9
	R-LX-06X130-CS-ZF	7.5	130	87	75	9
	R-LX-06X140-CS-ZF	7.5	140	97	85	9
	R-LX-06X150-CS-ZF	7.5	150	107	95	9
	R-LX-06X160-CS-ZF	7.5	160	117	105	9
8	R-LX-08X060-CS-ZF	9.9	60	10	-	12
	R-LX-08X075-CS-ZF	9.9	75	25	5	12
	R-LX-08X090-CS-ZF	9.9	90	40	20	12
	R-LX-08X100-CS-ZF	9.9	100	50	30	12
	R-LX-08X130-CS-ZF	9.9	130	80	60	12
	R-LX-08X150-CS-ZF	9.9	150	100	80	12
10	R-LX-10X065-CS-ZF	12.4	65	10	-	14
	R-LX-10X075-CS-ZF	12.4	75	20	-	14
	R-LX-10X085-CS-ZF	12.4	85	30	-	14
	R-LX-10X100-CS-ZF	12.4	100	45	15	14
	R-LX-10X120-CS-ZF	12.4	120	65	35	14
	R-LX-10X140-CS-ZF	12.4	140	85	55	14
	R-LX-10X160-CS-ZF	12.4	160	105	75	14

Installation data

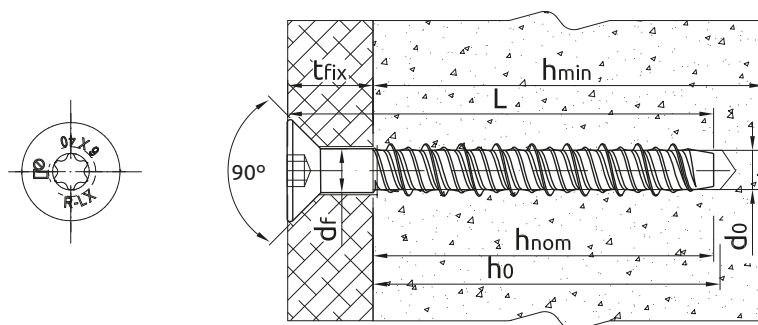

Normal concrete

Size			5	6	8	10
Hole diameter in substrate	d_0	[mm]	5	6	8	10
Hole diameter in fixture	d_f	[mm]	7	9	12	14
Screw drive	-	[-]	T25	T40	T50	T50
Head diameter		[mm]	10.9	15.9	21.3	21.3
Max. torque for impact screw driver	$T_{imp,max}$	[Nm]	200	400	900	950

Installation data

Size			5	6	8	10
MINIMUM EMBEDMENT DEPTH						
Min. hole depth in substrate	$h_{0,min}$	[mm]	-	45	-	-
Real hole depth in substrate	h_0	[mm]	-	$L + 10 - t_{fix}$	-	-
Min. installation depth	$h_{nom,min}$	[mm]	-	35	-	-
Min. substrate thickness	$h_{min,min}$	[mm]	-	80	-	-
Min. spacing	$s_{min,min}$	[mm]	-	45	-	-
Min. edge distance	$c_{min,min}$	[mm]	-	45	-	-
REDUCED EMBEDMENT DEPTH						
Min. hole depth in substrate	$h_{0,r}$	[mm]	35	50	60	65
Real hole depth in substrate	h_0	[mm]	$L + 10 - t_{fix}$	$L + 10 - t_{fix}$	$L + 10 - t_{fix}$	$L + 10$
Min. installation depth	$h_{nom,r}$	[mm]	25	39	50	55
Min. substrate thickness	$h_{min,r}$	[mm]	80	80	80	80
Min. spacing	$s_{min,r}$	[mm]	40	45	50	60
Min. edge distance	$c_{min,r}$	[mm]	40	45	50	60
STANDARD EMBEDMENT DEPTH						
Min. hole depth in substrate	$h_{0,s}$	[mm]	50	65	80	95
Real hole depth in substrate	h_0	[mm]	$L + 10 - t_{fix}$	$L + 10 - t_{fix}$	$L + 10 - t_{fix}$	$L + 10 - t_{fix}$
Min. installation depth	$h_{nom,s}$	[mm]	40	55	70	85
Min. substrate thickness	$h_{min,s}$	[mm]	80	84	110	130
Min. spacing	$s_{min,s}$	[mm]	40	45	50	60
Min. edge distance	$c_{min,s}$	[mm]	40	45	50	60

Hollow concrete slab

Size			6
Thread diameter	d	[mm]	7.5
Hole diameter in substrate	d_0	[mm]	6
Screw drive	-	[-]	T25
Head diameter		[mm]	10.9
Max. torque for impact screw driver	$T_{imp,max}$	[Nm]	400
MINIMUM EMBEDMENT DEPTH			
Min. hole depth in substrate	$h_{0,min}$	[mm]	45
Real hole depth in substrate	h_0	[mm]	$L + 10 - t_{fix}$
Min. installation depth	$h_{nom,min}$	[mm]	35
Minimum distance between anchor groups	$a_{min,min}$	[mm]	100
Min. spacing	$s_{min,min}$	[mm]	100
Min. edge distance	$c_{min,min}$	[mm]	100

Mechanical properties

Size			5	6	8	10
Nominal ultimate tensile strength - tension	f_{uk}	[N/mm ²]	1300	1250	1200	1050
Nominal yield strength - tension	f_{yk}	[N/mm ²]	1150	1100	1050	950
Cross sectional area - tension	A_s	[mm ²]	19.6	28.3	50.3	78.5
Elastic section modulus	W_{el}	[mm ³]	12.2	21.2	50.3	98.1
Characteristic bending resistance	$M^0_{Rk,s}$	[Nm]	19	31.8	72.4	123.6
Design bending resistance	M	[Nm]	12.7	21.2	48.3	82.4

Basic performance data

Performance data for single anchor without influence of edge distance and spacing

Size		5	6	8	10
CRACKED AND NON-CRACKED CONCRETE					
Reduced embedment depth h_{nom}	[mm]	25.00	39.00	50.00	55.00
Standard embedment depth h_{nom}	[mm]	40.00	55.00	70.00	85.00
Minimum embedment depth h_{nom}	[mm]	-	35.00	-	-
HOLLOW CORE SLAB					
Minimum embedment depth h_{nom}	[mm]	-	35.00	-	-
CHARACTERISTIC LOAD					
TENSION AND SHEAR LOAD F_{Rk}					
CRACKED AND NON-CRACKED CONCRETE					
Reduced embedment depth	[kN]	3.00	6.00	7.50	9.00
Standard embedment depth	[kN]	5.00	9.00	12.00	20.00
Minimum embedment depth	[kN]	-	3.00	-	-
HOLLOW CORE SLAB					
Minimum embedment depth	[kN]	-	6.00	-	-
DESIGN LOAD					
TENSION AND SHEAR LOAD F_{Rd}					
CRACKED AND NON-CRACKED CONCRETE					
Reduced embedment depth	[kN]	1.67	4.00	5.00	6.00
Standard embedment depth	[kN]	2.77	6.00	8.00	13.30
Minimum embedment depth	[kN]	-	2.00	-	-
HOLLOW CORE SLAB					
Minimum embedment depth	[kN]	-	4.00	-	-
RECOMMENDED LOAD					
TENSION AND SHEAR LOAD F_{rec}					
CRACKED AND NON-CRACKED CONCRETE					
Reduced embedment depth	[kN]	1.19	2.85	3.57	4.28
Standard embedment depth	[kN]	1.98	4.29	5.71	9.52
Minimum embedment depth	[kN]	-	1.42	-	-
HOLLOW CORE SLAB					
Minimum embedment depth	[kN]	-	2.85	-	-

Design performance data

Normal concrete

Size			5		6		8		10		
Min. installation depth	h_{nom}	[mm]	25.00	40.00	35.00	39.00	55.00	50.00	70.00	55.00	80.00
Effective embedment depth	h_{ef}	[mm]	17.50	30.00	24.70	30.00	42.00	37.00	53.00	40.00	65.00
TENSION AND SHEAR LOAD											
Characteristic resistance	F_{Rk}	[kN]	3.00	5.00	3.00	6.00	9.00	7.50	12.00	9.00	20.00
Installation safety factor	γ_{inst}	-	1.20	1.20	1.00	1.00	1.00	1.00	1.00	1.00	1.00
Increasing factors for $N_{Rd,p}$ - C30/37	ψ_c	-	1.08	1.08	1.00	1.08	1.08	1.08	1.08	1.08	1.08
Increasing factors for $N_{Rd,p}$ - C40/50	ψ_c	-	1.15	1.15	1.00	1.15	1.15	1.15	1.15	1.15	1.15
Increasing factors for $N_{Rd,p}$ - C50/60	ψ_c	-	1.19	1.19	1.00	1.19	1.19	1.19	1.19	1.19	1.19
Spacing	$s_{cr,N}$	-	70.00	90.00	100.0	90.00	126.0	120.0	160.0	120.0	196.0
Edge distance	$c_{cr,N}$	-	35.00	45.00	50.00	45.00	63.00	60.00	80.00	60.00	98.00
SHEAR LOAD											
STEEL FAILURE											
Characteristic resistance with lever arm	$M_{Rk,s}$	[Nm]	19.00	19.00	31.80	31.80	31.80	72.40	72.40	123.6	123.6
Partial safety factor	γ_{Ms}	-	1.50	1.50	1.50	1.50	1.50	1.50	1.50	1.50	1.50

Characteristic Resistance under fire exposure in concrete C20/25 to C50/60

Size			5		6		8		10		
TENSION AND SHEAR LOAD											
Spacing	s_{cr}	[mm]	120.00	120.00	168.00	148.00	212.00	160.00	260.00	160.00	260.00
Edge distance	c_{cr}	[mm]	60.00	60.00	84.00	74.00	106.00	80.00	130.00	80.00	130.00
R (for EI) = 30 min											
Effective embedment depth	h_{ef}	[mm]	30.00	30.00	42.00	37.00	53.00	40.00	65.00	40.00	65.00
TENSION AND SHEAR LOAD											
Characteristic resistance	F_{Rk}	[kN]	0.20	0.28	0.28	0.75	0.75	1.57	1.57	1.57	1.57
R (for EI) = 60 min											
Effective embedment depth	h_{ef}	[mm]	30.00	30.00	42.00	37.00	53.00	40.00	65.00	40.00	65.00
TENSION AND SHEAR LOAD											
Characteristic resistance	F_{Rk}	[kN]	0.18	0.25	0.25	0.65	0.75	1.18	1.18	1.18	1.18
R (for EI) = 90 min											
Effective embedment depth	h_{ef}	[mm]	30.00	30.00	42.00	37.00	53.00	40.00	65.00	40.00	65.00
TENSION AND SHEAR LOAD											
Characteristic resistance	F_{Rk}	[kN]	0.14	0.20	0.20	0.50	0.75	1.02	1.02	1.02	1.02
R (for EI) = 120 min											
Effective embedment depth	h_{ef}	[mm]	30.00	30.00	42.00	37.00	53.00	40.00	65.00	40.00	65.00
TENSION AND SHEAR LOAD											
Characteristic resistance	F_{Rk}	[kN]	0.10	0.14	0.14	0.40	0.75	0.79	0.79	0.79	0.79

Design performance data

Hollow concrete slab

Size			6
Min. installation depth	h_{nom}	[mm]	35.00
Effective embedment depth	h_{ef}	[mm]	24.70
Min. bottom flange thickness	d_b	[mm]	35.00
TENSION AND SHEAR LOAD			
HOLLOW CONCRETE SLAB C30/37			
Characteristic resistance	F_{Rk}	[kN]	5.00
HOLLOW CONCRETE SLAB C40/50			
Characteristic resistance	F_{Rk}	[kN]	6.00
HOLLOW CONCRETE SLAB C50/60			
Characteristic resistance	F_{Rk}	[kN]	6.00
Installation safety factor	V_{inst}	-	1.00
Spacing	$s_{cr,N}$	[mm]	100.00
Edge distance	$c_{cr,N}$	[mm]	50.00
SHEAR LOAD			
STEEL FAILURE			
Characteristic resistance with lever arm	$M_{Rk,s}$	[Nm]	31.80
Partial safety factor	V_{Ms}	-	1.50

Product commercial data

Product Code	Anchor	Quantity [pcs]			Weight [kg]			Bar Codes
	Length [mm]	Box	Outer	Pallet	Box	Outer	Pallet	
R-LX-05X050-CS-ZF ₁₎	50	100	100	38400	0.89	0.89	372.9	5906675130217
R-LX-05X075-CS-ZF ₁₎	75	100	100	38400	1.27	1.27	516.5	5906675130224
R-LX-06X050-CS-ZF ₁₎	50	100	100	38400	1.59	1.59	640.6	5906675130231
R-LX-06X075-CS-ZF ₁₎	75	100	100	38400	1.83	1.83	734.3	5906675130248
R-LX-06X100-CS-ZF ₁₎	100	100	100	25600	2.4	2.4	639.8	5906675130255
R-LX-06X120-CS-ZF ₁₎	120	100	100	25600	3.0	3.0	785.2	5906675478180
R-LX-06X130-CS-ZF ₁₎	130	100	100	25600	3.0	3.0	799.8	5906675130262
R-LX-06X140-CS-ZF ₁₎	140	100	100	25600	3.2	3.2	849.2	5906675478203
R-LX-06X150-CS-ZF ₁₎	150	100	100	25600	3.4	3.4	897.8	5906675130279
R-LX-06X160-CS-ZF ₁₎	160	100	100	25600	3.5	3.5	926.0	5906675478227
R-LX-08X060-CS-ZF ₁₎	60	100	100	25600	2.7	2.7	725.6	5906675130385
R-LX-08X075-CS-ZF ₁₎	75	100	100	25600	3.3	3.3	880.2	5906675130392
R-LX-08X090-CS-ZF ₁₎	90	100	100	19200	4.0	4.0	791.3	5906675130408
R-LX-08X100-CS-ZF ₁₎	100	100	100	19200	4.4	4.4	866.2	5906675130415
R-LX-08X130-CS-ZF ₁₎	130	50	50	12800	2.8	2.8	744.2	5906675130422
R-LX-08X150-CS-ZF ₁₎	150	50	50	12800	3.1	3.1	812.1	5906675130439
R-LX-10X065-CS-ZF ₁₎	65	50	50	14400	2.3	2.3	701.6	5906675130453
R-LX-10X075-CS-ZF ₁₎	75	50	50	12800	2.6	2.6	704.0	5906675130460
R-LX-10X085-CS-ZF ₁₎	85	50	50	12800	2.8	2.8	757.0	5906675130477

Product commercial data

Product Code	Anchor	Quantity [pcs]			Weight [kg]			Bar Codes
	Length [mm]	Box	Outer	Pallet	Box	Outer	Pallet	
R-LX-10X100-CS-ZF ₁₎	100	50	50	12800	3.3	3.3	873.5	5906675130491
R-LX-10X120-CS-ZF ₁₎	120	25	25	6400	2.0	2.0	529.8	5906675130514
R-LX-10X140-CS-ZF ₁₎	140	25	25	9600	2.3	2.3	922.8	5906675130521
R-LX-10X160-CS-ZF ₁₎	160	20	20	7680	2.1	2.1	842.9	5906675130538

1) ETA 17/0783