

R-LX-CS-ZP Zinc Plated Countersunk Concrete Screw Anchor. Part 6

Self-tapping concrete screwbolt



Approvals and Reports

- ETA 17/0783
- UKTA-22/6346



Product information

Features and benefits

- Time-efficient installation through streamlined procedure - simply drill and drive
- Completely removable with possibility of reuse
- Unique design with patented threadform ensures high performance for relatively small hole diameter
- Non-expansion functioning ensures low risk of damage to base material and makes R-LX ideal for installation near edges and adjacent anchors
- High performance in non-cracked concrete
- Different head types for any application
- Oversize head for fixtures with elongated holes
- Excellent product for temporary fixing
- Suitable for standard and reduced embedment depth

Applications

- Through-fixing
- Temporary anchorages
- Formwork support systems
- Balustrading & handrails
- Fencing & gates manufacturing and installation
- Racking systems
- Public seating
- Scaffolding

Base materials

Approved for use in:

- Cracked concrete C20/25-C50/60
- Non-cracked concrete C20/25-C50/60
- Reinforced concrete
- Unreinforced concrete

Installation guide

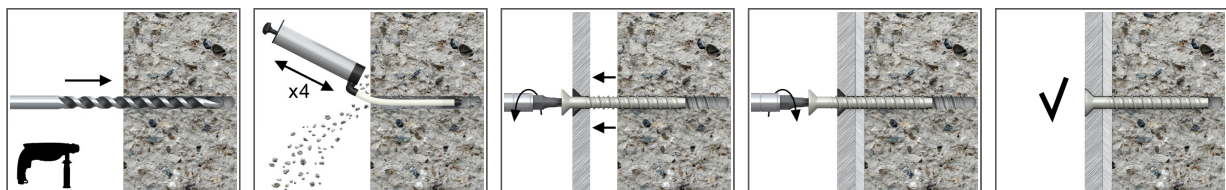

1. Drill the hole with rotary hammer drilling machine. Drill to a required depth.
2. Blow out dust at least 4 times with a hand pump.
3. Possibility of unscrewing and re-screwing.
4. Tighten to the recommended torque.
5. After installation.

Product information

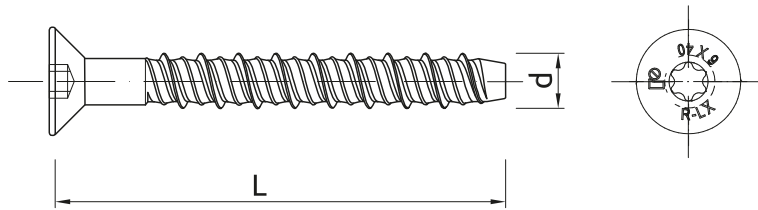

Size	Product Code	Anchor		Fixture		
		Diameter	Length	Max. thickness t_{fix} for:		Hole diameter
		d [mm]	L [mm]	$h_{nom,red}$ [mm]	$h_{nom,std}$ [mm]	d_f [mm]
5	R-LX-05X050-CS-ZP	6.2	50	-	7	7
	R-LX-05X075-CS-ZP	6.2	75	-	32	7
6	R-LX-06X050-CS-ZP	7.5	50	7	-	9
	R-LX-06X060-CS-ZP	7.5	60	17	5	9
	R-LX-06X075-CS-ZP	7.5	75	32	20	9
	R-LX-06X090-CS-ZP	7.5	90	47	35	9
	R-LX-06X100-CS-ZP	7.5	100	57	45	9
	R-LX-06X120-CS-ZP	7.5	120	77	65	9
	R-LX-06X130-CS-ZP	7.5	130	87	75	9
	R-LX-06X140-CS-ZP	7.5	140	97	85	9
	R-LX-06X150-CS-ZP	7.5	150	107	95	9
	R-LX-06X160-CS-ZP	7.5	160	117	105	9

Installation data

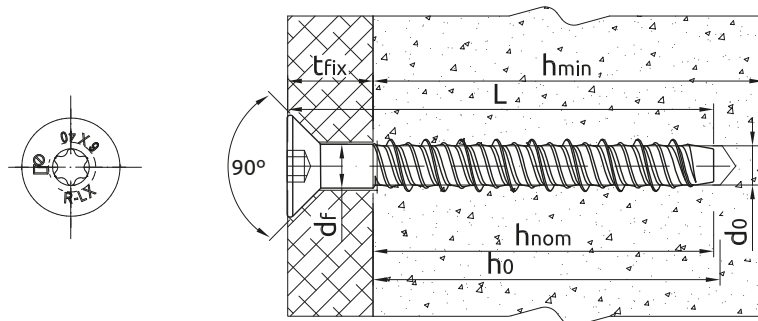

Size			5	6
Thread diameter	d	[mm]	6.2	7.5
Hole diameter in substrate	d_0	[mm]	5	6
Screw drive	-	[-]	T25	T40
Head diameter		[mm]	10.9	15.9
Max. torque for impact screw driver	$T_{imp,max}$	[Nm]	200	400
STANDARD EMBEDMENT DEPTH				
Min. hole depth in substrate	$h_{0,s}$	[mm]	50	65
Real hole depth in substrate	h_0	[mm]	$L + 10 - t_{fix}$	$L + 10 - t_{fix}$
Min. installation depth	$h_{nom,s}$	[mm]	43	55
Min. substrate thickness	$h_{min,s}$	[mm]	100	100
Min. spacing	$s_{min,s}$	[mm]	40	45
Min. edge distance	$c_{min,s}$	[mm]	40	45

Installation data

Size			5	6
REDUCED EMBEDMENT DEPTH				
Min. hole depth in substrate	$h_{0,r}$	[mm]	-	50
Real hole depth in substrate	h_0	[mm]	-	$L + 10 - t_{fix}$
Min. installation depth	$h_{nom,r}$	[mm]	-	43
Min. substrate thickness	$h_{min,r}$	[mm]	-	100
Min. spacing	$s_{min,r}$	[mm]	-	45
Min. edge distance	$c_{min,r}$	[mm]	-	45

Mechanical properties

Size			5	6
Nominal ultimate tensile strength - tension	f_{uk}	[N/mm ²]	1300	1250
Nominal yield strength - tension	f_{yk}	[N/mm ²]	1150	1100
Cross sectional area - tension	A_s	[mm ²]	19.6	28.3
Elastic section modulus	W_{el}	[mm ³]	12.2	21.2
Characteristic bending resistance	$M^0_{Rk,s}$	[Nm]	19	31.8
Design bending resistance	M	[Nm]	12.7	21.2

Basic performance data

Performance data for single anchor without influence of edge distance and spacing

Size			5	6
NON-CRACKED CONCRETE C20/25				
Standard embedment depth h_{nom}	[mm]		43.00	55.00
Reduced embedment depth h_{nom}	[mm]		-	35.00
CRACKED CONCRETE C20/25				
Standard embedment depth h_{nom}	[mm]		43.00	55.00
Reduced embedment depth h_{nom}	[mm]		-	35.00
MEAN ULTIMATE LOAD				
TENSION LOAD $N_{Ru,m}$				
NON-CRACKED CONCRETE C20/25				
Standard embedment depth	[kN]		10.10	14.80
Reduced embedment depth	[kN]		-	12.22
CRACKED CONCRETE C20/25				
Standard embedment depth	[kN]		7.10	11.10
Reduced embedment depth	[kN]		-	8.60
SHEAR LOAD $V_{Ru,m}$				
NON-CRACKED CONCRETE C20/25				
Standard embedment depth	[kN]		14.66	18.37
Reduced embedment depth	[kN]		-	12.22
CRACKED CONCRETE C20/25				
Standard embedment depth	[kN]		10.32	12.93
Reduced embedment depth	[kN]		-	8.60

Basic performance data

Size		5	6
CHARACTERISTIC LOAD			
TENSION LOAD N_{Rk}			
NON-CRACKED CONCRETE C20/25			
Standard embedment depth	[kN]	7.00	12.00
Reduced embedment depth	[kN]	-	8.90
CRACKED CONCRETE C20/25			
Standard embedment depth	[kN]	4.50	7.00
Reduced embedment depth	[kN]	-	6.23
SHEAR LOAD V_{Rk}			
NON-CRACKED CONCRETE C20/25			
Standard embedment depth	[kN]	8.90	13.39
Reduced embedment depth	[kN]	-	8.90
CRACKED CONCRETE C20/25			
Standard embedment depth	[kN]	6.23	9.37
Reduced embedment depth	[kN]	-	6.23
DESIGN LOAD			
TENSION LOAD N_{Rd}			
NON-CRACKED CONCRETE C20/25			
Standard embedment depth	[kN]	3.89	8.00
Reduced embedment depth	[kN]	-	5.94
CRACKED CONCRETE C20/25			
Standard embedment depth	[kN]	2.50	4.67
Reduced embedment depth	[kN]	-	4.16
SHEAR LOAD V_{Rd}			
NON-CRACKED CONCRETE C20/25			
Standard embedment depth	[kN]	5.94	8.93
Reduced embedment depth	[kN]	-	5.94
CRACKED CONCRETE C20/25			
Standard embedment depth	[kN]	4.16	6.25
Reduced embedment depth	[kN]	-	4.16

Design performance data

(-) failure is not decisive

Size			5		6	
Min. installation depth	h_{nom}	[mm]	43.00	-	35.00	55.00
Effective embedment depth	h_{ef}	[mm]	32.00	-	24.70	42.00
TENSION LOAD						
STEEL FAILURE						
Characteristic resistance	$N_{Rk,s}$	[kN]	25.50	-	35.40	35.40
Partial safety factor	γ_{Ms}	-	1.40	-	1.40	1.40
PULL-OUT FAILURE; NON-CRACKED CONCRETE C20/25						
Characteristic resistance	$N_{Rk,p}$	[kN]	7.00	-	-	12.00
PULL-OUT FAILURE; CRACKED CONCRETE C20/25						
Characteristic resistance	$N_{Rk,p}$	[kN]	4.50	-	-	7.00
PULL-OUT FAILURE						
Installation safety factor	γ_{inst}	-	1.20	-	1.00	1.00
Increasing factors for $N_{Rd,p}$ - C30/37	ψ_c	-	1.08	-	1.08	1.08
Increasing factors for $N_{Rd,p}$ - C40/50	ψ_c	-	1.15	-	1.15	1.15
Increasing factors for $N_{Rd,p}$ - C50/60	ψ_c	-	1.19	-	1.19	1.19
CONCRETE CONE FAILURE						
Installation safety factor	γ_{inst}	-	1.20	-	1.00	1.00
Factor for cracked concrete	$k_{cr,N}$	-	7.70	-	7.70	7.70
Factor for non-cracked concrete	$k_{ucr,N}$	-	11.00	-	11.00	11.00
Spacing	$s_{cr,N}$	[mm]	90.00	-	90.00	126.0
Edge distance	$c_{cr,N}$	[mm]	45.00	-	45.00	63.00
CONCRETE SPLITTING FAILURE						
Installation safety factor	γ_{inst}	-	1.20	-	1.00	1.00
Spacing	$s_{cr,sp}$	[mm]	90.00	-	90.00	126.0
Edge distance	$c_{cr,sp}$	[mm]	45.00	-	45.00	63.00
SHEAR LOAD						
STEEL FAILURE						
Characteristic resistance without lever arm	$V_{Rk,s}$	[kN]	12.70	-	17.70	17.70
Ductility factor	k_γ	-	0.80	-	0.80	0.80
Characteristic resistance with lever arm	$M_{Rk,s}$	[Nm]	19.00	-	31.80	31.80
Partial safety factor	γ_{Ms}	-	1.50	-	1.50	1.50
CONCRETE PRY-OUT FAILURE						
Factor	k	-	1.00	-	1.00	1.00
Installation safety factor	γ_{inst}	-	1.00	-	1.00	1.00
CONCRETE EDGE FAILURE						
Effective length of anchor	ℓ_f	[mm]	43.00	-	43.00	35.00
Anchor diameter	d_{nom}	[mm]	5.00	-	6.00	6.00
Installation safety factor	γ_{inst}	-	1.00	-	1.00	1.00

Design performance data

Characteristic Resistance under fire exposure in concrete C20/25 to C50/60

Size			5		6	
TENSION LOAD						
Edge distance	c_{cr}	[mm]	-	-	-	-
Spacing	s_{cr}	[mm]	-	-	-	-
R (for EI) = 30 min						
TENSION LOAD						
STEEL FAILURE						
Characteristic resistance	$N_{Rk,s}$	[kN]	-	0.20	0.28	0.28
PULL-OUT FAILURE						
Characteristic resistance	$N_{Rk,p}$	[kN]	-	1.13	1.38	1.75
 SHEAR LOAD						
STEEL FAILURE						
Characteristic resistance without lever arm	$V_{Rk,s}$	[kN]	-	0.20	0.28	0.28
Characteristic resistance with lever arm	$M_{Rk,s}$	[Nm]	-	0.15	0.25	0.25
Effective embedment depth	h_{ef}	[mm]	-	32.00	24.70	42.00
R (for EI) = 60 min						
TENSION LOAD						
STEEL FAILURE						
Characteristic resistance	$N_{Rk,s}$	[kN]	-	0.18	0.25	0.25
PULL-OUT FAILURE						
Characteristic resistance	$N_{Rk,p}$	[kN]	-	1.13	1.38	1.75
 SHEAR LOAD						
STEEL FAILURE						
Characteristic resistance without lever arm	$V_{Rk,s}$	[kN]	-	0.18	0.25	0.25
Characteristic resistance with lever arm	$M_{Rk,s}$	[Nm]	-	0.13	0.23	0.23
Effective embedment depth	h_{ef}	[mm]	-	32.00	24.70	42.00
R (for EI) = 90 min						
TENSION LOAD						
STEEL FAILURE						
Characteristic resistance	$N_{Rk,s}$	[kN]	-	0.14	0.20	0.20
PULL-OUT FAILURE						
Characteristic resistance	$N_{Rk,p}$	[kN]	-	1.13	1.38	1.75
 SHEAR LOAD						
STEEL FAILURE						
Characteristic resistance without lever arm	$V_{Rk,s}$	[kN]	-	0.14	0.20	0.20
Characteristic resistance with lever arm	$M_{Rk,s}$	[Nm]	-	0.10	0.18	0.18
Effective embedment depth	h_{ef}	[mm]	-	32.00	24.70	42.00
R (for EI) = 120 min						
TENSION LOAD						
STEEL FAILURE						
Characteristic resistance	$N_{Rk,s}$	[kN]	-	0.10	0.14	0.14
PULL-OUT FAILURE						
Characteristic resistance	$N_{Rk,p}$	[kN]	-	0.90	1.10	1.40
 SHEAR LOAD						
STEEL FAILURE						
Characteristic resistance without lever arm	$V_{Rk,s}$	[kN]	-	0.10	0.14	0.14
Characteristic resistance with lever arm	$M_{Rk,s}$	[Nm]	-	0.07	0.13	0.13
Effective embedment depth	h_{ef}	[mm]	-	32.00	24.70	42.00

Product commercial data

Product Code	Anchor	Quantity [pcs]			Weight [kg]			Bar Codes
	Length [mm]	Box	Outer	Pallet	Box	Outer	Pallet	
R-LX-05X050-CS-ZP ₁₎	50	100	100	38400	0.91	0.91	379.4	5906675127859
R-LX-05X075-CS-ZP ₁₎	75	100	100	38400	1.29	1.29	526.9	5906675128054
R-LX-06X050-CS-ZP ₁₎	50	100	100	38400	1.59	1.59	640.6	5906675128801
R-LX-06X060-CS-ZP ₁₎	60	100	100	38400	1.52	1.52	611.8	5906675442488
R-LX-06X075-CS-ZP ₁₎	75	100	100	38400	1.76	1.76	705.8	5906675129280
R-LX-06X090-CS-ZP ₁₎	90	100	100	38400	2.2	2.2	856.8	5906675442495
R-LX-06X100-CS-ZP ₁₎	100	100	100	25600	2.3	2.3	618.8	5906675129297
R-LX-06X120-CS-ZP ₁₎	120	100	100	25600	2.9	2.9	759.6	5906675478173
R-LX-06X130-CS-ZP ₁₎	130	100	100	25600	3.0	3.0	785.2	5906675129303
R-LX-06X140-CS-ZP ₁₎	140	100	100	25600	3.3	3.3	862.0	5906675478197
R-LX-06X150-CS-ZP ₁₎	150	100	100	25600	3.5	3.5	919.9	5906675129310
R-LX-06X160-CS-ZP ₁₎	160	100	100	25600	3.6	3.6	938.8	5906675478210

1) ETA 17/0783