

R-FX-N-K-A2 Nylon hammer-in fixing with mushroom head

The hammer fixing with mushroom head made from best quality nylon for fast, simple, cost-effective installations



Product information

Features and benefits

- Rapid hammer-set installation reduces the time required and allows for cost-effective, high-volume installation.
- Combination of PZ recess and the helical thread makes removal of the nail possible, facilitating disassembly when necessary.
- The extensive range of lengths and diameters mushroom head type plug ensures availability of the correct fixing for every scenario
- Designed for push-through installation.
- Nylon material for best quality

Applications

- Timber or metal battens
- Drywall structures
- Skirting / Dado railing
- Cable clamps
- Pipe clamps
- Sheeting

Base materials

Approved for use in:

- Concrete
- Solid Brick
- Solid Sand-lime Brick
- Lightweight Concrete Block
- Hollow Lightweight Concrete Block
- Aerated Concrete Block

Installation guide

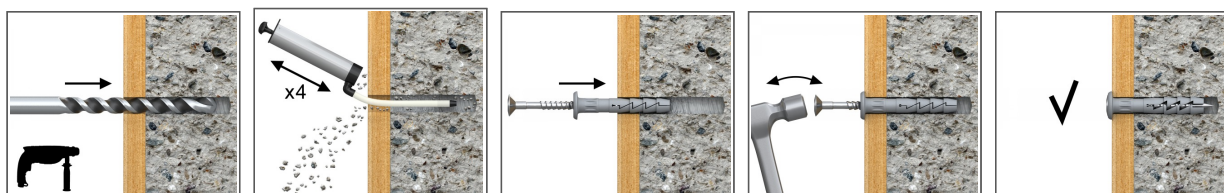

1. Drill a hole of required diameter.
2. Insert FX plug into hole through fixture.
3. Hammer the nail into the plastic sleeve until fixing is secure and flush with the fixture.

Product information

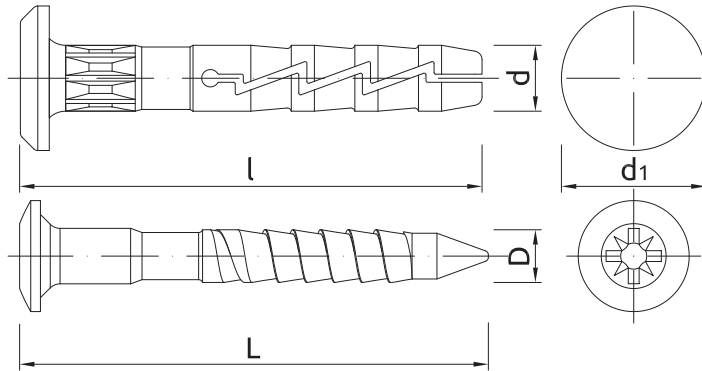

Size	Product Code	Plug		Nail		Fixture		Diameter
		Diameter	Length	Diameter	Length	Max. thickness	Hole diameter	
		d	l	D	L	t _{fix}	d _f	d ₁
[mm]								
Ø6	R-FX-N-06K040	5.9	40	3.8	44	11	7	12.5
	R-FX-N-06K060	5.9	60	3.8	64	31	7	12.5

Installation data

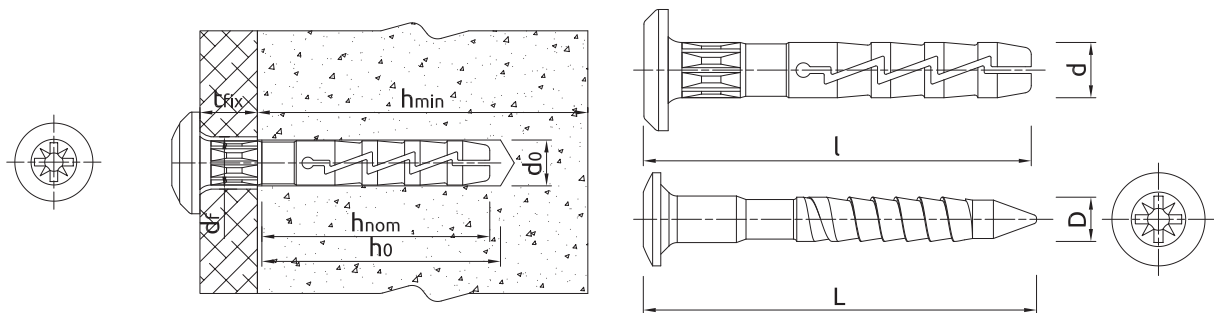

Installation data

Product dimensions

Size	Ø6		
Hole diameter in substrate	d ₀	[mm]	6
Min. hole depth in substrate	h ₀	[mm]	35
Min. installation depth	h _{nom}	[mm]	29
Min. substrate thickness	h _{min}	[mm]	100
Min. spacing	s _{min}	[mm]	100
Min. edge distance	c _{min}	[mm]	100
Fixing diameter	d	[mm]	6

Basic performance data

Performance data for single fixing in tension without influence of edge distance and spacing

Substrate		Concrete C12/15	Concrete C16/20	Concrete C20/25 - C50/60	Solid clay brick min 20MPa (eg Mz20/2.0)	Solid brick min. 30MPa	Sand-lime solid brick	Sand-lime hollow brick	Lightweight concrete hollow block	Lightweight concrete block	Autoclaved aerated concrete
POLYAMIDE PLUG											
MEAN ULTIMATE LOAD $N_{Ru,m}$											
TENSION LOAD $N_{Ru,m}$											
Ø06, Effective embedment depth 29 mm	[kN]	0.37	0.53	0.53	0.39	0.39	0.55	0.53	0.40	0.49	0.14
CHARACTERISTIC LOAD N_{Rk}											
TENSION LOAD N_{Rk}											
Ø06, Effective embedment depth 29 mm	[kN]	0.20	0.30	0.30	0.20	0.20	0.40	0.30	0.30	0.30	0.10
DESIGN LOAD N_{Rd}											
TENSION LOAD N_{Rd}											
Ø06, Effective embedment depth 29 mm	[kN]	0.10	0.15	0.15	0.10	0.10	0.20	0.15	0.15	0.15	0.05
RECOMMENDED LOAD N_{rec}											
TENSION LOAD N_{rec}											
Ø06, Effective embedment depth 29 mm	[kN]	0.07	0.11	0.11	0.07	0.07	0.14	0.11	0.11	0.11	0.04

Product commercial data

Product Code	Plug	Quantity [pcs]			Weight [kg]			Bar Codes
	Diameter [mm]	Box	Outer	Pallet	Box	Outer	Pallet	
R-FX-N-06K040	5.9	100	1600	38400	0.47	7.5	209.7	5906675177427
R-FX-N-06K060	5.9	100	1200	28800	0.64	7.7	215.2	5906675177441