

R-OCR-55/63 Zinc flake self-drilling screws up to 6mm

Special zinc flake corrosion-resistant coating for highly effective protection



Approvals and Reports

- ETA-17/0518



Product information

Features and benefits

- Hardened screw's thread surface. High quality anti-corrosion coating guarantees resistance of 15 Kesternich cycles.
- Coloured polyester protective coating with a thickness of 45-50 um (RAL, NCS, RR), provides additional protection against corrosion. Various colours available to suit all metal sheet variants. UV stabilizers ensure colour quality over a long period of use.
- The shape of the thread and its height is designed for applications into sandwich panels and steel construction.
- Special zinc flake corrosion-resistant coating for anti-corrosion protection
- Self vulcanizing EPDM washer. Temperature and UV resistant. The special shape of the washer ensures proper seating of the sealing material on the outer cladding material fixture which guarantees a proper seal.
- Drilling point - especially approach angle of self-drilling tip allows direct installation without predrilling up to 6mm

Applications

- For fixing of: Composite panels to cold formed sections structures

Base materials

- Approved for use in:**
- Structural Steel up to 6mm

Installation guide

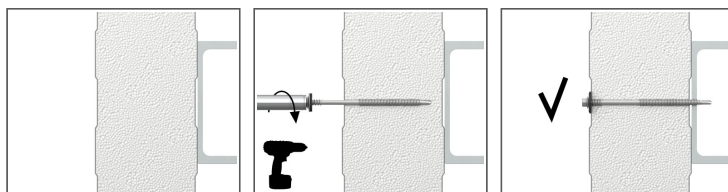

1. Magnetic driver must be used.
2. Lowest torque setting on impact screwdriver to start.
3. Reduce speed when the washer starts to deform.
4. Use a cordless Impact screwdriver. Note: Never use a power drill.
5. For installation please use screwdriver of load capacity 1600 - 2000 rpm with regulated trogue.

Product information

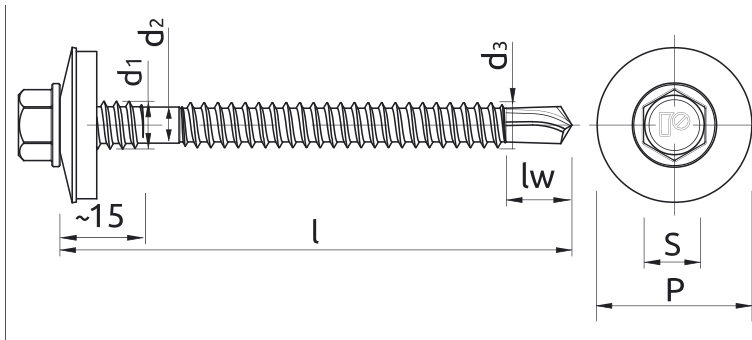

Size	Product Code	Screw				Fixture	Max. drilling thickness	Washer size
		Diameter		Length	Head size	Max. thickness with washer		
		d	d ₁	l	S	t _{fix}		
[mm]								
Ø5.5/6.3	R-OCR-55/63090A19	5.5	6.3	90	8	65	6	19
	R-OCR-55/63110A19	5.5	6.3	110	8	85	6	19
	R-OCR-55/63125A19	5.5	6.3	125	8	100	6	19
	R-OCR-55/63150A19	5.5	6.3	150	8	125	6	19
	R-OCR-55/63175A19	5.5	6.3	175	8	150	6	19
	R-OCR-55/63200A19	5.5	6.3	200	8	175	6	19
	R-OCR-55/63230A19	5.5	6.3	230	8	205	6	19
	R-OCR-55/63275A19	5.5	6.3	275	8	250	6	19

Installation data

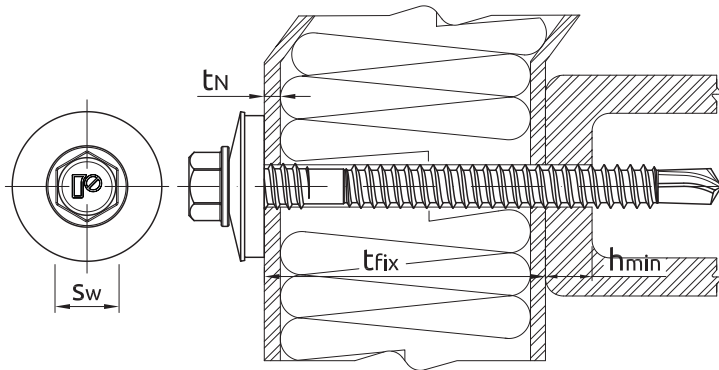

Size	Ø5.5/6.3		
Wrench size	Sw	[mm]	8
Min. substrate thickness	h _{min}	[mm]	1.5
Max. substrate thickness	h _{max}	[mm]	6
Min. spacing	s _{min}	[mm]	30
Min. edge distance	c _{min}	[mm]	10
Screw diameter	d	[mm]	5.5/6.3

Basic performance data

Performance data for single screw without influence of edge distance and spacing

Size	TENSION LOAD		SHEAR LOAD	
		Ø5.5/6.3 (A19)		Ø5.5/6.3 (A19)
MEAN ULTIMATE LOAD				
Substrate thickness ≥ 1.5 mm; $t_n \geq 0.4$	[kN]	2.79		1.26
Substrate thickness ≥ 1.5 mm; $t_n \geq 0.5$	[kN]	3.20		2.09
Substrate thickness ≥ 1.5 mm; $t_n \geq 0.63$	[kN]	3.20		2.70
Substrate thickness ≥ 1.5 mm; $t_n \geq 0.75$	[kN]	3.20		3.35
Substrate thickness ≥ 4.0 mm; $t_n \geq 0.5$	[kN]	4.79		2.09
Substrate thickness ≥ 4.0 mm; $t_n \geq 0.63$	[kN]	6.06		2.70
Substrate thickness ≥ 4.0 mm; $t_n \geq 0.75$	[kN]	6.23		3.35
CHARACTERISTIC LOAD				
Substrate thickness ≥ 1.5 mm; $t_n \geq 0.4$	[kN]	1.86		0.86
Substrate thickness ≥ 1.5 mm; $t_n \geq 0.5$	[kN]	2.13		1.38
Substrate thickness ≥ 1.5 mm; $t_n \geq 0.63$	[kN]	2.13		1.80
Substrate thickness ≥ 1.5 mm; $t_n \geq 0.75$	[kN]	2.13		2.23
Substrate thickness ≥ 4.0 mm; $t_n \geq 0.5$	[kN]	3.19		1.38
Substrate thickness ≥ 4.0 mm; $t_n \geq 0.63$	[kN]	4.04		1.80
Substrate thickness ≥ 4.0 mm; $t_n \geq 0.75$	[kN]	4.15		2.23
DESIGN LOAD				
Substrate thickness ≥ 1.5 mm; $t_n \geq 0.4$	[kN]	1.40		0.67
Substrate thickness ≥ 1.5 mm; $t_n \geq 0.5$	[kN]	1.60		1.04
Substrate thickness ≥ 1.5 mm; $t_n \geq 0.63$	[kN]	1.60		1.35
Substrate thickness ≥ 1.5 mm; $t_n \geq 0.75$	[kN]	1.60		1.67
Substrate thickness ≥ 4.0 mm; $t_n \geq 0.5$	[kN]	2.40		1.04
Substrate thickness ≥ 4.0 mm; $t_n \geq 0.63$	[kN]	3.04		1.35
Substrate thickness ≥ 4.0 mm; $t_n \geq 0.75$	[kN]	3.12		1.67
RECOMMENDED LOAD				
Substrate thickness ≥ 1.5 mm; $t_n \geq 0.4$	[kN]	1.00		0.47
Substrate thickness ≥ 1.5 mm; $t_n \geq 0.5$	[kN]	1.14		0.74
Substrate thickness ≥ 1.5 mm; $t_n \geq 0.63$	[kN]	1.14		0.97
Substrate thickness ≥ 1.5 mm; $t_n \geq 0.75$	[kN]	1.14		1.20
Substrate thickness ≥ 4.0 mm; $t_n \geq 0.5$	[kN]	1.71		0.74
Substrate thickness ≥ 4.0 mm; $t_n \geq 0.63$	[kN]	2.17		0.97
Substrate thickness ≥ 4.0 mm; $t_n \geq 0.75$	[kN]	2.23		1.20

Product commercial data

Product Code	Screw Diameter [mm]	Washer size [mm]	Quantity [pcs]			Weight [kg]			Bar Codes
			Box	Outer	Pallet	Box	Outer	Pallet	
R-OCR-55/63090A19 ₁₎	6.3	19	100	800	25600	1.65	13.2	453.2	5906675409252
R-OCR-55/63110A19 ₁₎	6.3	19	100	800	25600	1.89	15.1	514.6	5906675409269
R-OCR-55/63125A19 ₁₎	6.3	19	100	800	25600	2.1	16.6	562.0	5906675409276
R-OCR-55/63150A19 ₁₎	6.3	19	100	800	25600	2.4	19.1	641.6	5906675409283
R-OCR-55/63175A19 ₁₎	6.3	19	100	800	25600	2.7	21.4	715.6	5906675409290
R-OCR-55/63200A19 ₁₎	6.3	19	100	800	25600	3.0	23.8	791.1	5906675409306
R-OCR-55/63230A19 ₁₎	6.3	19	100	100	28800	3.4	3.4	999.1	5906675409313
R-OCR-55/63275A19 ₁₎	6.3	19	100	100	11200	4.2	4.2	496.5	5906675409337

1) ETA-17/0518