

ZAGZAVOD ZA
GRADBENIŠTVO
SLOVENIJESLOVENIAN
NATIONAL BUILDING
AND CIVIL ENGINEERING
INSTITUTEčlan EOTA
Member of EOTA**Dimičeva 12**
1000 Ljubljana, Slovenija

Tel.: +386 (0)1-280 44 72, 280 45 37

Fax: +386 (0)1-280 44 84

E-pošta: info.ta@zag.si

http://www.zag.si/ts

European Technical Assessment

ETA-14/0345
of 13.10.2014*English version prepared by ZAG*

I GENERAL PART

Komerčno ime

Trade name

Imetnik tehnične ocene

Holder of Technical Assessment

Družina proizvoda

Product family

Proizvodni obrat

Manufacturing plant

Ta Evropska tehnična ocena vsebuje

This European Technical Assessment contains

Ta Evropska tehnična ocena je izdana na podlagi Uredbe (EU) št. 305/2011 na osnovi

*This European Technical Assessment is issued in accordance to Regulation (EU) No 305/2011, on the basis of***Safety Plus II****Rawplug Limited****Skibo Drive****Thornliebank Industrial Estate****Glasgow G46 8JR****Torzijsko kontrolirano zatezno kovinsko sidro iz galvansko pocinkanega jekla velikosti M6, M8, M10, M12 in M16 za vgradnjo beton***Torque controlled expansion anchor made of galvanised steel of sizes M6, M8, M10, M12 and M16 for use in concrete***Manufacturing Plant No.2**

14 strani vključno s 11 prilogami, ki so sestavni del te ocene

14 pages including 11 annexes, which form an integral part of the document

Smernice za evropska tehnična soglasja ETAG 001 – del 1 in 2, izdaja 2013, ki se uporablja kot EAD

Guideline for European Technical Approval ETAG 001 – part 1 and 2, edition 2013, used as EAD

Translations of this European Technical Assessment in other languages shall fully correspond to the original issued document and should be identified as such.

Communication of this European Technical Assessment, including transmission by electronic means, shall be in full (excepted the confidential Annex(es) referred to above). However, partial reproduction may be made, with the written consent of the issuing Technical Assessment Body. Any partial reproduction has to be identified as such.

II SPECIFIC PART OF THE EUROPEAN TECHNICAL ASSESSMENT

1 Technical description of the product

The Safety Plus II in the range of M6, M8, M10, M12 and M16 is an anchor made of galvanised steel, which is placed into a drilled hole and anchored by torque-controlled expansion.

An illustration and description of the anchor are given in Annex A.

2 Specification of the intended use

The performances given in Chapter 3 are only valid if the anchor is used in compliance with the specifications and conditions given in Annex B.

The provisions made in this European Technical Assessment are based on an assumed working life of the anchor of 50 years. The indications given on the working life cannot be interpreted as a guarantee given by the manufacturer, but are to be regarded only as a means for choosing the right products in relation to the expected economically reasonable working life of the works.

3 Performance of the product and references to the methods used for this assessment

3.1 Mechanical resistance and stability (BWR 1)

The essential characteristics for mechanical resistance and stability are listed in Annexes C1 to C4.

3.2 Safety in case of fire (BWR 2)

The essential characteristics for safety in case of fire are listed in Annex C5.

3.3 Hygiene, health and environment (BWR 3)

Regarding dangerous substances contained in this European Technical Assessment, there may be requirements applicable to the products falling within its scope (e.g. transported European legislation and national laws, regulations and administrative provisions). In order to meet provisions of the regulation (EU) No 305/2011, these requirements need also to be complied with, when they apply.

3.4 Safety in use (BWR 4)

For basic requirement safety in use the same criteria are valid as for basic requirement mechanical resistance and stability.

3.5 Protection against noise (BWR 5)

Not relevant.

3.6 Energy economy and heat retention (BWR 6)

Not relevant.

3.7 Sustainable use of natural resources (BWR 7)

For sustainable use of natural resources no performance was determined for this product.

3.8 General aspects relating to fitness for use

Durability and serviceability are only ensured if specifications of intended use according to Annex B1 are kept.

4 Assessment and verification of constancy of performance (AVCP)

According to the decision 96/582/EC of the European Commission¹ the system of assessment and verification of constancy of performance (see Annex V to regulation (EU) No 305/2011) given in the following table apply.

¹

Official Journal of the European Communities L 254 of 8.10.1996

Product	Intended use	Level of class	System
Metal anchors for use in concrete	For fixing and/or supporting to concrete, structural elements (which contributes to the stability of the works) or heavy units	-	1

5 Technical details necessary for the implementation of the AVCP system

5.1 Tasks for the manufacturer

The manufacturer shall exercise permanent internal control of production of concerned product. All the elements, requirements and provisions adopted by the manufacturer shall be documented in a systematic manner in the form of written policies and procedures, including records of results performed. This production control system shall ensure that the product is in conformity with this European Technical Assessment.

The manufacturer may only use raw materials stated in the technical documentation of this European Technical Assessment.

The factory production control shall be in accordance with the Control plan which is a part of the technical documentation of this European Technical Assessment. The Control plan² is laid down in the context of the factory production control system operated by the manufacturer and deposited at Slovenian National Building and Civil Engineering Institute (ZAG Ljubljana). The results of factory production Control shall be recorded and evaluated in accordance with the provisions of the control plan.

The manufacturer shall, on the basis of a contract, involve a body, which is notified for the tasks referred to in a section 4 in the field of anchors in order to undertake the actions laid down in section 5.2. For this purpose the Control plan referred to in sections 5.1 and 5.2 shall be handed over by the manufacturer to the notified body involved.

The manufacturer shall make a Declaration of performance, stating that the construction product is in conformity with the provisions of this European Technical Assessment.

5.2 Tasks for the notified bodies

The notified body shall retain the essential points of its actions defined in Annex V of Regulation (EU) No. 305/2011 for system 1 and state results obtained and conclusions drawn in a written report.

The notified certification body involved by the manufacturer shall issue an EC certificate of constancy of performance the product stating the conformity with the provisions of this European Technical Assessment.

In cases where the provisions of the European Technical Assessment and its Control plan are no longer fulfilled the notified body shall withdraw the certificate of constancy of performance and inform the Slovenian National Building and Civil Engineering Institute (ZAG Ljubljana) without delay.

Issued in Ljubljana on 13.10.2014

Signed by:

Franc Capuder, M.Sc., Research Engineer

Head of Service of TAB

²

The Control plan is a confidential part of the technical documentation of this European Technical Assessment, but not published together with the ETA, and handed over only to the notified body or bodies involved in the procedure of attestation of conformity.

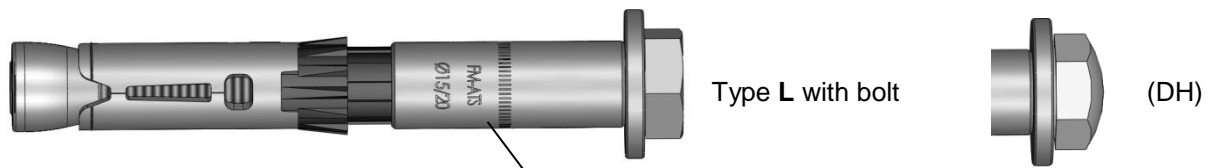

Type L with bolt

(DH)

Marking: Identification mark of the producer - trade name of the anchor
nominal drill hole diameter / max thickness of fixture
(and line for minimum embedment and max thickness of fixture)
e.g.: FM-ATS
Ø15/20



Type P with threaded bar



Type C with countersunk screw

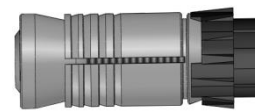

Sleeve for M16 size

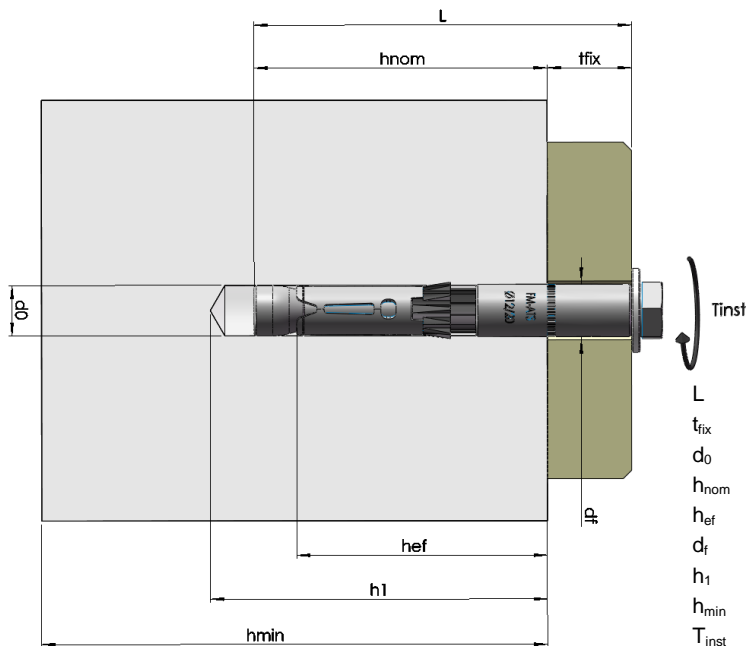

- L = length of the anchor (mm)
- t_{fix} = thickness of fixture (mm)
- d_0 = nominal drill hole diameter (mm)
- h_{nom} = minimum installation depth (mm)
- h_{ef} = effective anchorage depth (mm)
- d_f = diameter of clearance hole in the fixture (mm)
- h_1 = depth of drill hole (mm)
- h_{min} = minimum thickness of the concrete member (mm)
- T_{inst} = torque moment (Nm)

Safety Plus II

Product description
Product and intended use

Annex A1

R-SPL-II-L

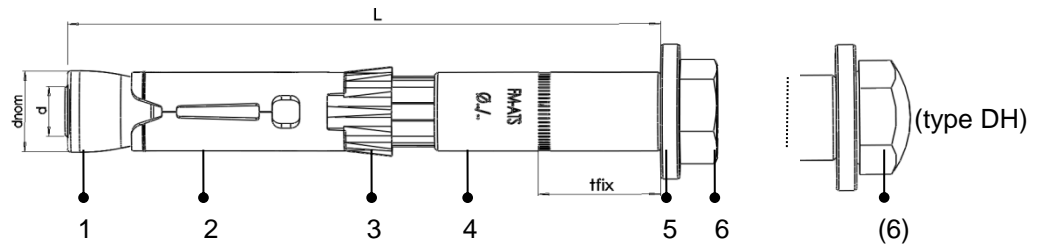

R-SPL-II-P

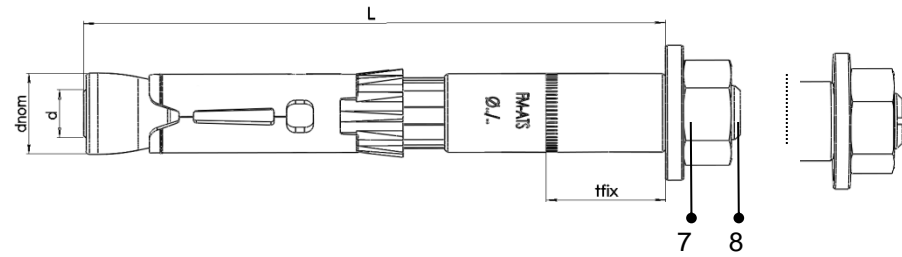

R-SPL-II-C

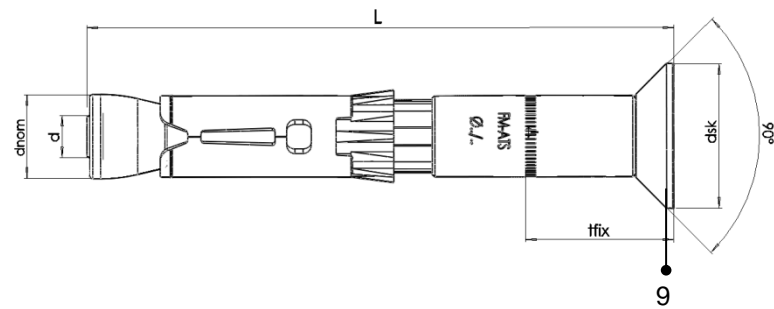

- 1 Cone
- 2 Expansion sleeve
- 3 Plastic sleeve
- 4 Distance sleeve
- 5 Washer
- 6 Hexagonal screw
- 7 Hexagonal nut
- 8 Threaded bar
- 9 Countersunk screw

Safety Plus II

Product description
Product and components

Annex A2

Table A1: Materials

Part of anchor		Material
1	Cone	hardened steel EN 10087 ¹⁾
2	Expansion sleeve	M6÷M12 hardened steel EN 10132 ¹⁾ - M16 steel EN 10087 ¹⁾
3	Plastic sleeve	Pa6 ISO 1874/1
4	Distance sleeve	Steel EN 10025 ¹⁾
5	Washer	Steel EN 10139 ¹⁾
6	Hexagon screw	Steel grade 8.8 EN ISO 898/1 ¹⁾ (DIN 931 -DIN 933 - type SH=head large)
7	Hexagonal nut	Steel grade 8 DIN 934 ¹⁾ (EN ISO 898/2)
8	Threaded bar	Steel grade 8.8 EN ISO 898/1 ¹⁾
9	Countersunk screw	Steel grade 8.8 EN ISO 898/1 ¹⁾

¹⁾ Zinc electroplated 5µm according to EN ISO 4042

Safety Plus II	Annex A3
Product description Materials	

Specifications of intended use

Anchorage subjected to:

- Static, quasi static, seismic load and fire.

Base materials:

- Cracked and non-cracked concrete.
- Reinforced and unreinforced normal weight concrete of strength class C20/25 at minimum and C50/60 at maximum according to EN 206-1:2000/A2:2005.

Use conditions (Environmental conditions):

- Structures subjected to dry internal conditions.

Design:

- Anchorages are designed under the responsibility of an engineer experienced in anchorages and concrete work.
- Anchorages under static and quasi-static actions are designed in accordance with ETAG 001, Annex C, design method A, Edition August 2010 or CEN/TS 1992-4.
- For seismic application the anchorages are designed in accordance with TR 045 "Design of metal anchors for use in concrete under seismic actions".
- For application with resistance under fire exposure the anchorages are designed in accordance with method given in TR 020 "Evaluation of anchorage in concrete concerning resistance to fire".
- Verifiable calculation notes and drawings are prepared taking into account of the load to be anchored. The position of the anchor is indicated on the design drawings (e.g. position of the anchor relative to reinforcement or to supports, etc.).

Installation:

- Anchor installation carried out by appropriately qualified personnel and under supervision of the person responsible for technical matters of the site.
- Use of the anchor only supplied by the manufacturer without exchanging the components of the anchor.
- Anchor installation in accordance with the manufacturer's specification and drawings and using the appropriate tools.
- Checks before placing the anchor to ensure that the strength class of the concrete in which the anchor is to be placed is in the range given and is not lower than of the concrete to which the characteristic loads apply.
- Check of concrete being well compacted, e.g. without significant voids.
- Effective anchorage depth, edge distances and spacing not less than the specified values without minus tolerances.
- Hole drilling by hammer drill.
- Cleaning of the hole of drilling dust.
- Positioning of the drill holes without damaging the reinforcement.
- Application of specified torque moment using a calibrated torque wrench.
- In case of aborted hole, drilling of new hole at a minimum distance of twice the depth of the aborted hole, or smaller distance provided the aborted drill hole is filled with high strength mortar and no shear or oblique tension loads in the direction of aborted hole.

Safety Plus II

**Intended use
Specification**

Annex B1

Table B1: Dimensions

Anchor size		M6	M8	M10	M12	M16	
Nominal diameter of anchor	d_{nom} [mm]	10	12	15	18	24	
Minimum installation depth	$h_{nom} \geq$ [mm]	60	70	80	100	115	
Length of the anchor	L [mm]	$t_{fix} + 60$	$t_{fix} + 70$	$t_{fix} + 80$	$t_{fix} + 100$	$t_{fix} + 115$	
Thickness of the fixture	Type L (DH)/P	$t_{fix,min}$ [mm]	0	0	0	0	
	Type C	$t_{fix,min}$ [mm]	5	6	7	8	
	Type L (DH)/P/C	$t_{fix,max}$ [mm]	200	250	300	350	
Nominal diameter of the head of the countersunk screw Type C		d_{sk} [mm]	17	21	26	31	-

Safety Plus II**Intended use**
Dimensions of the anchors**Annex B2**

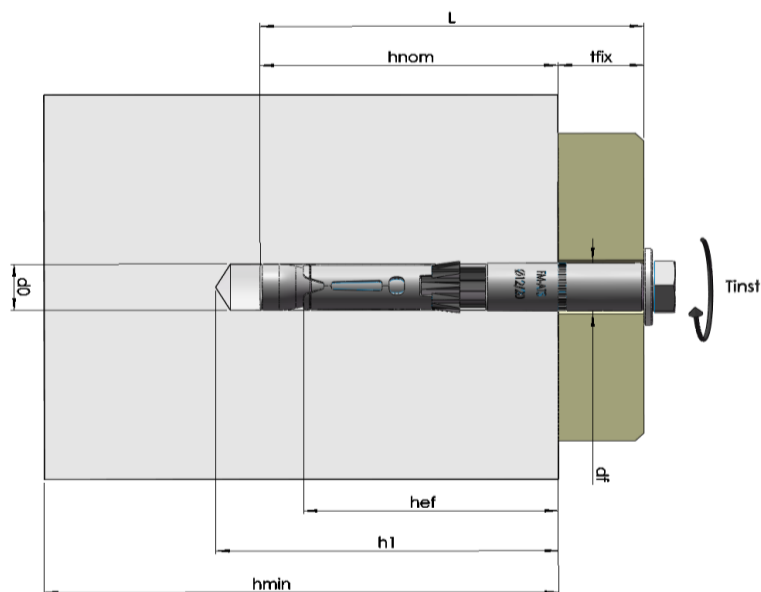

Table B2: Installation data

Anchor size		M6	M8	M10	M12	M16
Nominal drill hole diameter	d_0 [mm]	10	12	15	18	24
Cutting diameter of drill bit	$d_{cut} \leq$ [mm]	10,45	12,50	15,50	18,50	24,55
Depth of drill hole	$h_1 \geq$ [mm]	75	85	95	115	130
Minimum installation depth	$h_{nom} \geq$ [mm]	60	70	80	100	115
Effective anchorage depth	h_{ef} [mm]	49	59	67	88	99
Diameter of clearance hole in the fixture	$d_f \leq$ [mm]	12	14	17	20	26
Length of the anchor	L [mm]	$t_{fix} + 60$	$t_{fix} + 70$	$t_{fix} + 80$	$t_{fix} + 100$	$t_{fix} + 115$
Torque moment	T_{inst} [Nm]	10	20	45	80	150

Table B3: Minimum thickness of concrete member spacing, and edge distances

Anchor size		M6	M8	M10	M12	M16
Minimum thickness of the concrete member	h_{min} [mm]	100	120	140	180	200
Minimum spacing	s_{min} [mm]	50	60	70	80	100
	for c [mm] \geq	75	90	100	150	200
Minimum edge distance	c_{min} [mm]	50	60	70	80	100
	for $s \geq$ [mm]	75	90	100	150	200

Safety Plus II

Intended use
Installation parameters

Annex B3

Table C1: **Characteristic values for Tension loads in case of static and quasi-static loading for design method A acc. ETAG 001, Annex C or CEN/TS1992-4**

Essential characteristics			Performance				
			M6	M8	M10	M12	M16
Installation parameters							
d_0	Nominal diameter of drill bit	[mm]	10	12	15	18	24
h_{nom}	Anchorage depth	[mm]	60	70	80	100	115
h_{ef}	Effective anchorage depth	[mm]	49	59	67	88	99
h_{min}	Minimum thickness of concrete member	[mm]	100	120	140	180	200
T_{inst}	Torque moment	[Nm]	10	20	45	80	150
s_{min}	Minimum spacing	[mm]	50	60	70	80	100
for $c \geq$	Edge distance	[mm]	75	90	100	150	200
c_{min}	Minimum edge distance	[mm]	50	60	70	80	100
for $s \geq$	Spacing	[mm]	75	90	100	150	200
Tension steel failure mode							
$N_{RK,s}$	Characteristic tension steel failure	[kN]	16	29	46	67	126
γ_{MsN}	Partial safety factor	[-]	1,5				
Pull-out failure mode							
$N_{RK,p}$	Characteristic pull-out failure in non-cracked concrete	[kN]	1)	1)	1)	1)	1)
$N_{RK,p}$	Characteristic pull-out failure in cracked concrete	[kN]	9	12	16	25	1)
γ^2	Partial safety factor	[-]	1,0				
γ_{Mp}		[-]	1,5				
$s_{cr,N}$	Characteristic spacing	[mm]	3 x h_{ef}				
$c_{cr,N}$	Characteristic edge distance	[mm]	1,5 x h_{ef}				
ψ_C C30/37	Increasing factor for $N_{RK,p}$ in non-cracked concrete	[-]	1,22				
ψ_C C40/50		[-]	1,41				
ψ_C C50/60		[-]	1,55				
Concrete Cone failure mode							
k_{cr}	Factor for cracked concrete CEN/TS 1992-4-4 §. 6.2.1.4	[-]	7,2				
k_{ucr}	Factor for un-cracked concrete CEN/TS 1992-4-4 §. 6.2.1.4	[-]	10,1				
γ_{Mc}	Partial safety factor	[-]	1,5				
Splitting failure mode							
$s_{cr,sp}$	Characteristic spacing	[mm]	3 x h_{ef}				
$c_{cr,sp}$	Characteristic edge distance	[mm]	1,5 x h_{ef}				
γ_{Msp}	Partial safety factor	[-]	1,5				
Displacement under tension load							
Non-cracked concrete C20/25							
N	Service tension load	[kN]	7,7	10,9	13,2	19,8	23,6
δ_{N0}	Short term displacement	[mm]	0,47	0,81	0,30	0,25	0,20
$\delta_{N\infty}$	Long term displacement	[mm]	2,38	2,49	1,99	1,12	2,15
Cracked concrete C20/25							
N	Service tension load	[kN]	4,3	5,7	7,6	11,9	16,9
δ_{N0}	Short term displacement	[mm]	1,21	0,83	1,25	0,98	0,96
$\delta_{N\infty}$	Long term displacement	[mm]	2,38	2,49	1,99	1,12	2,15

1) Pull-out failure is not decisive

Safety Plus II

Design acc. to ETAG 001-Annex C or CEN/TS 1992-4
 Characteristic resistance under Tension loads – BWR 1

Annex C1

Table C2: **Characteristic values for Shear loads in case of static and quasi-static loading for design method A acc. ETAG 001-Annex C or CEN/TS 1992-4**

Essential characteristics			Performance				
			M6	M8	M10	M12	M16
Shear steel failure							
$V_{Rk,s}$	Characteristic shear steel failure	[kN]	14	26	42	50	97
$M^0_{Rk,s}$	Bending moment characteristic failure	[Nm]	12	30	60	105	266
γ_{MsV}	Partial safety factor	[-]	1,25				
Shear concrete pry-out and edge failure							
k	Factor in equation (5.6) of ETAG 001 Annex C § 5.2.3.3	[mm]	1,0		2,0		
K_3	Factor in equation (16) of CEN/TS 1992-4 § 6.2.2.3	[mm]	1,0		2,0		
l_{ef}	Effective anchorage depth	[mm]	49	59	67	88	99
d_{nom}	Diameter of anchor	[mm]	10	12	15	18	24
γ_{Mc}	Partial safety factor	[-]	1,5				
Displacement under shear load							
V	Service shear load	[kN]	8,0	14,9	24,0	28,6	55,4
δ_{V0}	Short term displacement	[mm]	1,39	1,94	2,71	1,69	2,69
$\delta_{V\infty}$	Long term displacement	[mm]	2,09	2,91	4,07	2,54	4,04

Safety Plus II
Design acc. to ETAG 001-Annex C or CEN/TS 1992-4
 Characteristic resistance under Shear loads – BWR 1
Annex C2

Table C3: **Characteristic values for resistance in case of Seismic performance category C1 acc. TR045 “Design of Metal anchor under Seismic Actions”**

Essential characteristics			Performance				
			M6	M8	M10	M12	M16
Tension steel failure							
$N_{Rk,s,seis\ C1}$	Characteristic tension steel failure	[kN]	16	29	46	67	126
$\gamma_{MsN,seis}^{2)}$	Partial safety factor	[-]	1,5				
Pull-out failure mode $N_{Rk,p,seis} = \psi_C \times N_{Rk,p,seis}^0$							
$N_{Rk,p,seis\ C1}$	Characteristic pull-out failure	[kN]	6,8	12	16	25	35,5 ¹⁾
$\gamma_{Mp,seis}^{2)}$	Partial safety factor	[-]	1,5				
Shear steel failure							
$V_{Rk,s,seis\ C1}$	Characteristic steel failure	[kN]	9,8	13	20	20	48,5
$\gamma_{MsV,seis}^{2)}$	Partial safety factor	[-]	1,25				

¹⁾ Pull-out failure is not decisive

²⁾ Recommended partial safety factors under seismic action ($\gamma_{M,seis}$) are the same as for static loading

Safety Plus II

Design according to TR 045
Characteristic resistance under Seismic actions – BWR 1

Annex C3

Table C4: Characteristic values for resistance in case of Seismic performance category C2 acc. TR045 “Design of Metal anchor under Seismic Actions”

Essential characteristics			Performance				
			M6	M8	M10	M12	M16
Tension steel failure							
$N_{Rk,s,seis} C2^{2)}$	Characteristic tension steel failure	[kN]	-	29	46	67	126
$\gamma_{MsN}^{3)}$	Partial safety factor	[-]	1,5				
Pull-out failure $N_{Rk,p,seis} = \psi_C \times N^0_{Rk,seis}$							
$N_{Rk,s,seis} C2^{2)}$	Characteristic pull-out failure	[kN]	-	3,9	7,8	15,3	28,8
$\gamma_{MpN}^{3)}$	Partial safety factor	[-]	1,5				
$\delta_{N,sei(DSL)}^{1)2)}$	Displacement at DSL	[mm]	-	2,7	4,9	3,6	3,1
$\delta_{N,sei(USL)}^{1)2)}$	Displacement at USL	[mm]	-	12,8	15,2	14,0	11,5
Shear steel failure							
$V_{Rk,s,seis} C2^{2)}$	Characteristic failure	[kN]	-	10,2	17,0	17,0	43,9
$\gamma_{MsV}^{3)}$	Partial safety factor	[-]	1,25				
$\delta_{V,sei(DSL)}^{1)2)}$	Displacement at DSL	[mm]	-	3,5	2,7	2,5	2,7
$\delta_{V,sei(USL)}^{1)2)}$	Displacement at USL	[mm]	-	6,8	6,3	5,8	6,1

1) Displacements represent mean values

2) Smaller displacement may be required in the design in the case of displacement sensitive fastenings or “rigid” supports. The characteristic resistance associated with such smaller displacement may be determined by linear interpolation or proportional reduction.

3) Recommended partial safety factors under seismic action ($\gamma_{M,seis}$) are the same as for static loading

Safety Plus II

Design according to TR 045
Characteristic resistance under Seismic actions - BWR 1

Annex C4

Table C5: **Characteristic resistance under Fire exposure for design design acc. to TR020**

Essential characteristics			Performance				
			M6	M8	M10	M12	M16
Tension steel failure mode							
NR_{k,s,fi,30}	Duration = 30 minutes	[kN]	0,20	0,37	0,87	1,69	3,14
NR_{k,s,fi,60}	Duration = 60 minutes	[kN]	0,18	0,33	0,75	1,26	2,36
NR_{k,s,fi,90}	Duration = 90 minutes	[kN]	0,14	0,26	0,58	1,10	2,04
NR_{k,s,fi,120}	Duration = 120 minutes	[kN]	0,10	0,18	0,46	0,84	1,57
Pull-out failure mode							
NR_{k,p,fi,30}	Duration = 30 minutes	[kN]	2,25	3,00	4,00	6,25	8,88
NR_{k,p,fi,60}	Duration = 60 minutes	[kN]	2,25	3,00	4,00	6,25	8,88
NR_{k,p,fi,90}	Duration = 90 minutes	[kN]	2,25	3,00	4,00	6,25	8,88
NR_{k,p,fi,120}	Duration = 120 minutes	[kN]	1,80	2,40	3,20	5,00	7,10
Concrete cone failure mode							
NR_{k,c,fi,30}	Duration = 30 minutes	[kN]	3,03	4,81	6,61	13,08	17,55
NR_{k,c,fi,60}	Duration = 60 minutes	[kN]	3,03	4,81	6,61	13,08	17,55
NR_{k,c,fi,90}	Duration = 90 minutes	[kN]	3,03	4,81	6,61	13,08	17,55
NR_{k,c,fi,120}	Duration = 120 minutes	[kN]	2,42	3,85	5,29	10,46	14,04
S_{cr,N}	Characteristic spacing	[mm]	4 x h _{ef}				
C_{cr,N}	Characteristic edge distance	[mm]	2 x h _{ef}				
S_{min}	Minimum spacing	[mm]	50	60	70	80	100
C_{min}	Minimum edge distance	[mm]	C _{min} = 2 h _{ef} ; if fire attack from more than one side, the edge distance of the anchor has to be ≥ 300mm and ≥ 2 h _{ef}				
γ_{M,fi}	Partial safety factor	[-]	1,0 ¹⁾				
Shear steel failure without lever arm							
VR_{k,s,fi,30}	Duration = 30 minutes	[kN]	0,20	0,37	0,87	1,69	3,14
VR_{k,s,fi,60}	Duration = 60 minutes	[kN]	0,18	0,33	0,75	1,26	2,36
VR_{k,s,fi,90}	Duration = 90 minutes	[kN]	0,14	0,26	0,58	1,10	2,04
VR_{k,s,fi,120}	Duration = 120 minutes	[kN]	0,10	0,18	0,46	0,84	1,57
Shear steel failure with lever arm							
M⁰_{VR_{k,s,fi,30}}	Duration = 30 minutes	[Nm]	0,15	0,37	1,12	2,62	6,66
M⁰_{VR_{k,s,fi,60}}	Duration = 60 minutes	[Nm]	0,14	0,34	0,97	1,96	5,00
M⁰_{VR_{k,s,fi,90}}	Duration = 90 minutes	[Nm]	0,11	0,26	0,75	1,70	4,33
M⁰_{VR_{k,s,fi,120}}	Duration = 120 minutes	[Nm]	0,08	0,19	0,60	1,31	3,33
Shear concrete pry-out failure							
k	Factor in equation (5.6) of ETAG Annex C § 5.2.3.3	[mm]	1,0		2,0		
Shear concrete edge failure							
The characteristic resistance V ⁰ _{VR_{k,c,fi}} in C 20/25 to C5 0/60 concrete is determined by: V ⁰ _{VR_{k,c,fi}} = 0,25 × V ⁰ _{VR_{k,c}} (≤ R90) and V ⁰ _{VR_{k,c,fi}} = 0,20 × V ⁰ _{VR_{k,c}} (R120) with V ⁰ _{VR_{k,c}} initial value of the characteristic resistance in cracked concrete C20/25 under normal temperature acc. ETAG 001, Annex C, 5.2.3.4.							

¹⁾ In the absence of other national regulations

Safety Plus II

Design according to TR020

Characteristic resistance under Fire exposure - BWR 2

Annex C5